

S.C. Brake Motor 25W (□80mm)

S.C. Brake Motor 25W (□80mm)

25W

Speed Control Brake Motor
25W(□80mm)

Motor 사양

Model 8SBDG*-25□: Gear Type Shaft 8SBD*-25: D-Cut Type Shaft	Output W	Voltage V	Frequency Hz	Poles	Duty	Speed Range r/min	Starting Torque		Permissible Torque				Capacitor μF / VAC
							kgfcm	N.m	1200r/min		90r/min		
Lead Wire Type									kgfcm	N.m	kgfcm	N.m	
8SBDG1(A)-25□	25	1φ110	60	4	30min.	90-1700	1.80	0.180	2.30	0.230	0.60	0.060	10.0 / 250
8SBDG2(D)-25□	25	1φ220	60	4	30min.	90-1700	1.80	0.180	2.30	0.230	0.60	0.060	2.5 / 450
8SBDGE-25□	25	1φ220	50	4	30min.	90-1400	1.60	0.160	2.10	0.210	0.55	0.055	2.5 / 450
		1φ240					1.80	0.180	2.30	0.230	0.65	0.065	

1) 모터 모델명 * 자리에는 전압코드가, □ 안에는 부착되는 감속기의 모델 타입명이 들어갑니다. 2) 전압코드 A, D, E는 TP(Thermal Protector) 부착 사양입니다.
3) Gear Type Shaft는 감속기 부착용이며 D-Cut Type Shaft는 모터 단독 사용시의 출력축입니다.

감속기 부착 시 최대허용토크

Motor Model	Gearbox Model	회전속도 r/min	전압 V	주파수 Hz	감속비	3	3.6	5	6	7.5	9	10	12.5	15	18	20	25	30	36
8SBDG*-25G	8GBK□ BMH	1200	110	60	kgfcm	5.6	6.7	9.3	11.2	14.0	16.8	18.6	23.3	27.9	33.5	33.6	42.0	50.4	60.4
					N.m	0.55	0.66	0.91	1.10	1.37	1.64	1.83	2.28	2.74	3.29	3.29	4.11	4.94	5.92
					kgfcm	5.6	6.7	9.3	11.2	14.0	16.8	18.6	23.3	27.9	33.5	33.6	42.0	50.4	60.4
		N.m	0.55	0.66	0.91	1.10	1.37	1.64	1.83	2.28	2.74	3.29	3.29	4.11	4.94	5.92			
		90	110	60	kgfcm	1.5	1.7	2.4	2.9	3.6	4.4	4.9	6.1	7.3	8.7	8.8	11.0	13.1	15.8
					N.m	0.14	0.17	0.24	0.29	0.36	0.43	0.48	0.60	0.71	0.86	0.86	1.07	1.29	1.55
kgfcm	1.5				1.7	2.4	2.9	3.6	4.4	4.9	6.1	7.3	8.7	8.8	11.0	13.1	15.8		
N.m	0.14	0.17	0.24	0.29	0.36	0.43	0.48	0.60	0.71	0.86	0.86	1.07	1.29	1.55					
220/240	110	50	kgfcm	1.6	1.9	2.6	3.2	3.9	4.7	5.3	6.6	7.9	9.5	9.5	11.9	14.2	17.1		
			N.m	0.15	0.19	0.26	0.31	0.39	0.46	0.52	0.64	0.77	0.93	0.93	1.16	1.40	1.67		

Motor Model	Gearbox Model	회전속도 r/min	전압 V	주파수 Hz	감속비	40	50	60	75	90	100	120	150	180	200	250	300	360		
8SBDG*-25G	8GBK□ BMH	1200	110	60	kgfcm	67.2	75.9	80.0	80.0	80.0	80.0	80.0	80.0	80.0	80.0	80.0	80.0	80.0	80.0	
					N.m	6.58	7.44	7.84	7.84	7.84	7.84	7.84	7.84	7.84	7.84	7.84	7.84	7.84	7.84	7.84
					kgfcm	67.2	75.9	80.0	80.0	80.0	80.0	80.0	80.0	80.0	80.0	80.0	80.0	80.0	80.0	80.0
			N.m	6.58	7.44	7.84	7.84	7.84	7.84	7.84	7.84	7.84	7.84	7.84	7.84	7.84	7.84	7.84	7.84	
			220/240	50	kgfcm	67.2	75.9	80.0	80.0	80.0	80.0	80.0	80.0	80.0	80.0	80.0	80.0	80.0	80.0	80.0
					N.m	6.58	7.44	7.84	7.84	7.84	7.84	7.84	7.84	7.84	7.84	7.84	7.84	7.84	7.84	7.84
		kgfcm			17.5	19.8	23.8	29.7	35.6	39.6	47.5	59.4	71.3	79.2	80.0	80.0	80.0			
		N.m	1.72	1.94	2.33	2.91	3.49	3.88	4.66	5.82	6.99	7.76	7.84	7.84	7.84					
		90	110	60	kgfcm	17.5	19.8	23.8	29.7	35.6	39.6	47.5	59.4	71.3	79.2	80.0	80.0			
					N.m	1.72	1.94	2.33	2.91	3.49	3.88	4.66	5.82	6.99	7.76	7.84	7.84			
					kgfcm	19.0	21.5	25.7	32.2	38.6	42.9	51.5	64.4	77.2	80.0	80.0	80.0			
			N.m	1.86	2.10	2.52	3.15	3.78	4.20	5.05	6.31	7.57	7.84	7.84	7.84					

Motor Model	Gearbox Model	회전속도 r/min	전압 V	주파수 Hz	감속비	10	12	15	18	25	30	36	50	60
8SBDG*-25W	8WD□BL/□ BR/□BRL	1200	110	60	kgfcm	18.9	22.1	26.6	30.6	40.3	45.5	53.0	69.0	75.9
					N.m	1.85	2.16	2.60	3.00	3.94	4.46	5.19	6.76	7.44
					kgfcm	19.1	22.9	28.6	34.4	47.7	57.3	68.7	95.5	81.6
			N.m	1.87	2.24	2.81	3.37	4.68	5.61	6.73	9.35	8.00		
			220/240	50	kgfcm	18.9	22.1	26.6	30.6	40.3	45.5	53.0	69.0	75.9
					N.m	1.85	2.16	2.60	3.00	3.94	4.46	5.19	6.76	7.44
		kgfcm			4.9	5.8	6.9	8.0	10.5	11.9	13.8	18.0	19.8	
		N.m	0.48	0.56	0.68	0.78	1.03	1.16	1.35	1.76	1.94			
		90	110	60	kgfcm	4.9	5.8	6.9	8.0	10.5	11.9	13.8	18.0	19.8
					N.m	0.48	0.56	0.68	0.78	1.03	1.16	1.35	1.76	1.94
					kgfcm	5.3	6.2	7.5	8.7	11.4	12.9	15.0	19.5	21.5
		N.m	0.52	0.61	0.74	0.85	1.11	1.26	1.47	1.91	2.10			

1) 모터 모델명 * 자리에는 전압코드가 들어갑니다. 2) 감속기 모델명 □ 안에는 감속비가 들어갑니다.
3) 위의 표에서 색칠된 범위의 감속비를 선택했을 때 감속기의 출력축은 모터의 출력축과 같은 방향으로 회전합니다.
흰색 바탕 범위의 감속비에서는 감속기 출력축은 모터 출력축의 회전방향과 반대방향으로 회전합니다.
4) 회전속도(r/min)는 모터의 동기회전속도(50Hz:1500r/min, 60Hz:1800r/min)를 감속비로 나누어 계산합니다. 실제 회전속도는 부하의 크기에 따라 표시보다 2~20% 정도 느립니다.

B AC Motors

S.C. Brake Motor 25W (□80mm)

Dimensions

MOTOR ONLY

- MOTOR MODEL: 8SBDD□-25 (NO FAN)

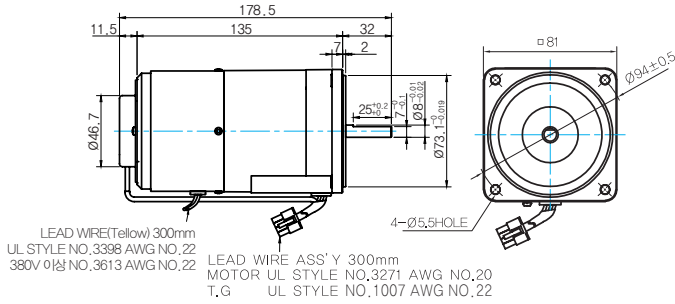

MOTOR OUTPUT SHAFT

MODEL	SPEC
D-CUT TYPE	

중간감속기

- MODEL: 8XD10□□

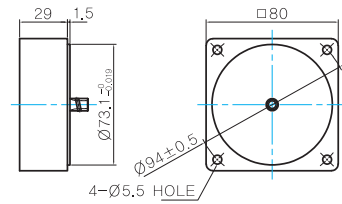

GEARED MOTOR

G TYPE GEARBOX

- MOTOR MODEL: 8SBDG□-25G (NO FAN)

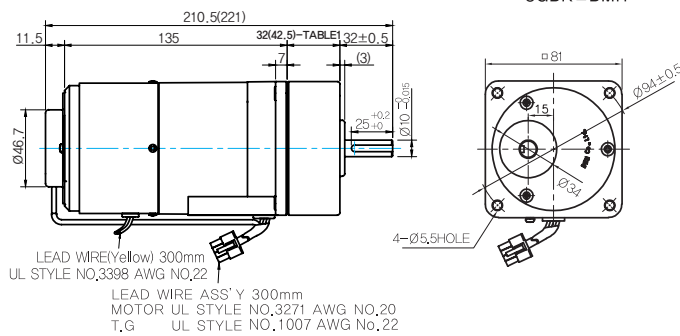

- GEARBOX MODEL: 8GBK□BMH

GEARBOX OUTPUT SHAFT

MODEL	SPEC
KEY TYPE	

KEY SPEC

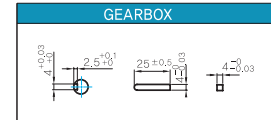

32(42.5)-Table1

SIZE(mm)	GEAR RATIO
32	8GBK3BMH ~ 8GBK18BMH
42.5	8GBK20BMH ~ 8GBK360BMH

W TYPE GEARBOX

- MOTOR MODEL: 8SBDG□-25W (NO FAN)

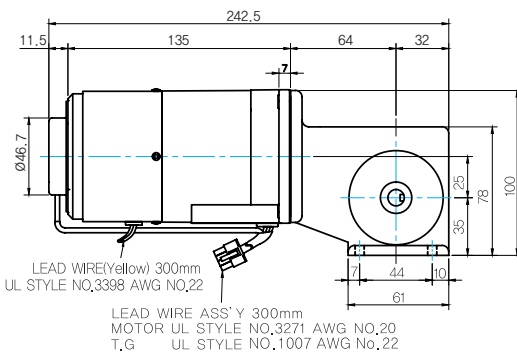

- GEARBOX MODEL: 8WD□BL/BR/BRL

KEY SPEC

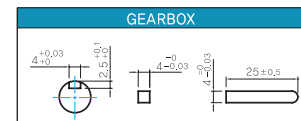

WEIGHT

PART	WEIGHT(Kg)	
MOTOR	2.1	
GEAR BOX	8GBK3BMH ~ 8GBK18BMH	0.56
	8GBK20BMH ~ 8GBK40BMH	0.65
	8GBK50BMH ~ 8GBK360BMH	0.72
	8WD□BL/BR/BRL	0.68
	8XD10□□	0.45

Motor Images

8SBDD□-25	8SBDG□-25G+8GBK□BMH	8SBDG□-25W+8WD□BL
		