

B AC Motors

Brake Motor 250W (□104mm)

250W Brake Motor 250W(□104mm)

Motor 사양

Model 10BDGE-250F□-T: Gear Type Shaft 10BDDE-250F-T: D-Cut Type Shaft 10BDKE-250F-T: Key Type Shaft	Output W	Voltage V	Frequency Hz	Poles	Duty	Starting Torque		Rated Load			Capacitor μF / VAC	
						kgfcm	N.m	Speed r/min	Current A	Torque kgfcm N.m		
Terminal Box Type 10BDKE-250F□-T	250	1φ220	50	4	30min.	11.00	1.100	1250	2.29	19.48	1.948	13.0 / 450
		1φ240				13.50	1.350	1300	2.17	18.74	1.874	

- 1) 모터 모델명 * 자리에는 전압코드가, □ 안에는 부착되는 감속기의 모델 타입명이 들어갑니다.
- 2) 전압코드 D, E는 TP(Thermal Protector) 부착 사양입니다.
- 3) Gear Type Shaft는 감속기 부착용이며 D-Cut & Key Type Shaft는 모터 단독 사용시의 출력축입니다.

감속기 부착 시 최대허용토크

50Hz

Motor Model	Gearbox Model	감속비 r/min	3	5	9	10	15	20	25	30	40	50	60	90	100	120	150	180
10BDGE-250FU-T	10UBK□BH	kgfcm	50.0	80.0	145.0	150.0	220.0	270.0	335.0	400.0	400.0	400.0	400.0	400.0	400.0	400.0	400.0	400.0
		N.m	4.90	7.84	14.21	14.70	21.56	26.46	32.83	39.20	39.20	39.20	39.20	39.20	39.20	39.20	39.20	39.20

Motor Model	Gearbox Model	감속비 r/min	5	7.5	10	15	20	25	30	40
10BDKE-250F-T	10WHD□-040	kgfcm	70.0	100.0	130.0	185.0	240.0	290.0	325.0	305.0
		N.m	6.86	9.80	12.74	18.13	23.52	28.42	31.85	29.89

Motor Model	Gearbox Model	감속비 r/min	15	20	25	30	40	50	60	80	100	120	160	200	225	240
10BDGE-250FHC-T	10HC□□	kgfcm	213	284	356	427	569	711	853	1138	1422	1706	2275	2844	3000	3000
		N.m	20.9	27.8	34.9	41.8	55.8	69.7	83.6	112	139	167	223	279	294	294

- 1) 감속기 모델명 □ 안에는 감속비가 들어갑니다.
- 2) 위의 표에서 색칠된 범위의 감속비를 선택했을 때 감속기의 출력축은 모터의 출력축과 같은 방향으로 회전합니다.
흰색 바탕 범위의 감속비에서는 감속기 출력축은 모터 출력축의 회전방향과 반대방향으로 회전합니다.
- 3) 회전속도(r/min)는 모터의 동기회전속도(50Hz:1500r/min, 60Hz:1800r/min)를 감속비로 나누어 계산합니다. 실제 회전속도는 부하의 크기에 따라 표시보다 2~20% 정도 느립니다.

Dimensions

MOTOR ONLY

MOTOR MODEL:
10BDKE-250F-T

LEAD WIRE(Yellow) 300mm
UL STYLE NO.3398 AWG NO.22
380V 이상 NO.3613 AWG NO.22

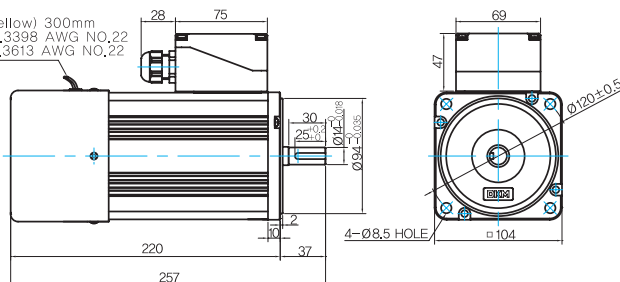

MOTOR OUTPUT SHAFT

MODEL	SPEC
D-CUT TYPE	37 25 ^{+0.2} 37 ^{+0.03} Ø120 ^{+0.03}
KEY TYPE	37 25 ^{+0.2} 37 ^{+0.03} Ø120 ^{+0.03}

KEY SPEC

MOTOR
5 ^{+0.03} 3 ^{+0.1} 25 ^{+0.5} 12 ^{+0.03} 5 ^{+0.03}

GEARED MOTOR

U TYPE GEARBOX

- MOTOR MODEL:
10BDGE-250FU-T

LEAD WIRE(Yellow) 300mm
UL STYLE NO.3398 AWG NO.22
380V 이상 NO.3613 AWG NO.22

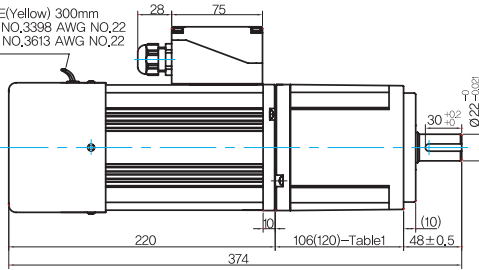

- GEARBOX MODEL:
10UBK □BH

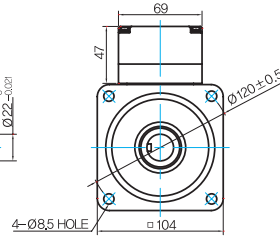

GEARBOX OUTPUT SHAFT

MODEL	SPEC
KEY TYPE	

KEY SPEC

GEARBOX

106(120)-Table1

SIZE(mm)	GEAR RATIO
106	10UBK3BH - 10UBK60BH
120	10UBK90BH - 10UBK180BH

WH TYPE GEARBOX

- MOTOR MODEL:
10BDKE-250F-T

LEAD WIRE(Yellow) 300mm
UL STYLE NO.3398 AWG NO.22
380V 이상 NO.3613 AWG NO.22

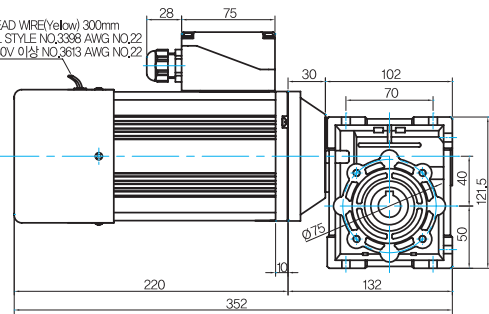

- GEARBOX MODEL:
10WHD □-040

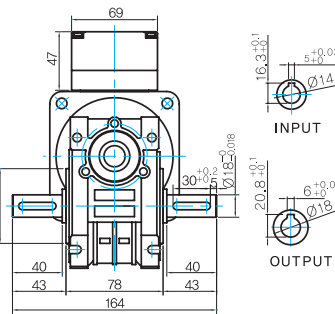

SHAFT

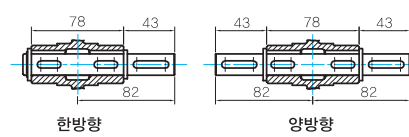

FLANGE

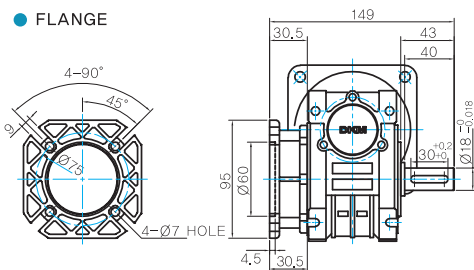

KEY SPEC

GEARBOX

HC TYPE GEARBOX

- GEARBOX MODEL :
10BDGE-250FHC-T (GENERAL FAN)

LEAD WIRE(YELLOW) 300mm
UL STYLE NO.3398 AWG NO.22
380V 이상 NO.3613 AWG NO.22

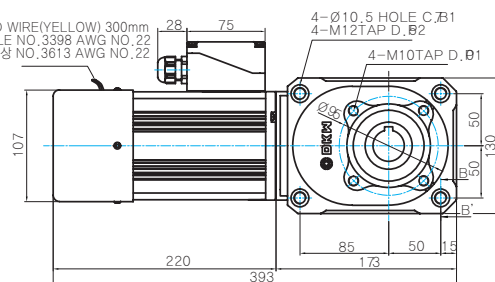

- GEARBOX MODEL :
10HC(15 ~ 60) □

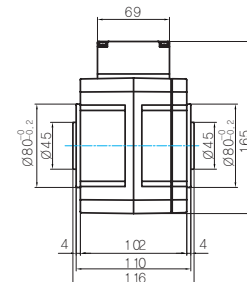

SHAFT

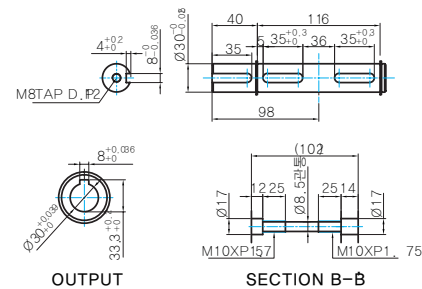

B AC Motors

Brake Motor 250W (□104mm)

● GEARBOX MODEL :
10BDGE-250FHC-T (GENERAL FAN)

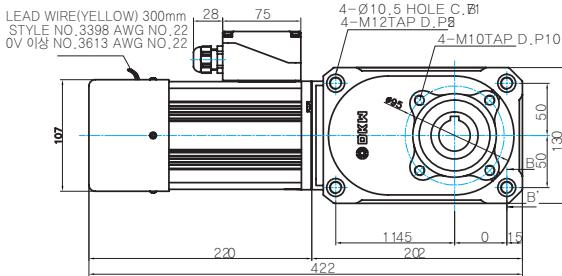

● GEARBOX MODEL :
10HC(80 ~ 240)□

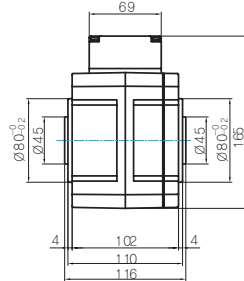

● KEY SPEC

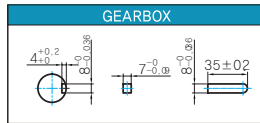

WEIGHT

PART	WEIGHT(Kg)
MOTOR	7.1
10UBK3BH ~ 10UBK9BH	2.0
10UBK10BH ~ 10UBK15BH	2.15
10UBK20BH ~ 10UBK60BH	2.3
10UBK90BH ~ 10UBK180BH	2.5
10HC15□	5.5
10HC20□ ~ 10HC60□	5.6
10HC80□ ~ 10HC240□	6.4

* 출력 FLANGE와 SHAFT는 별매입니다

Motor Images

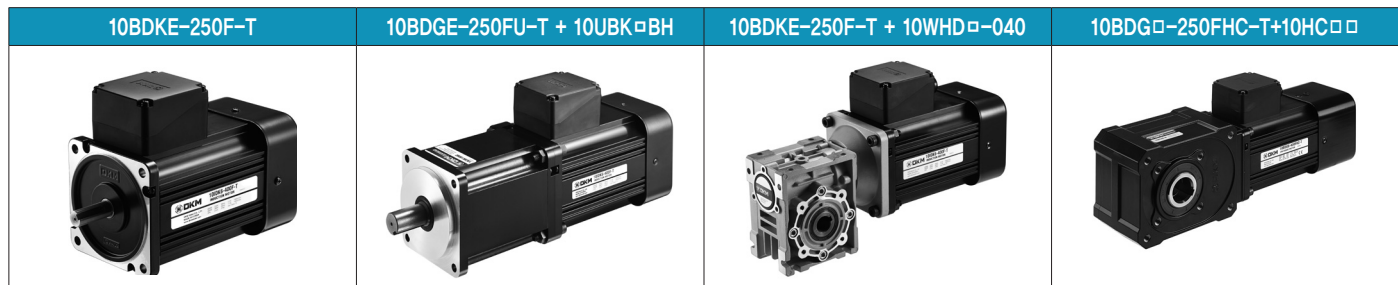

Connection Diagrams

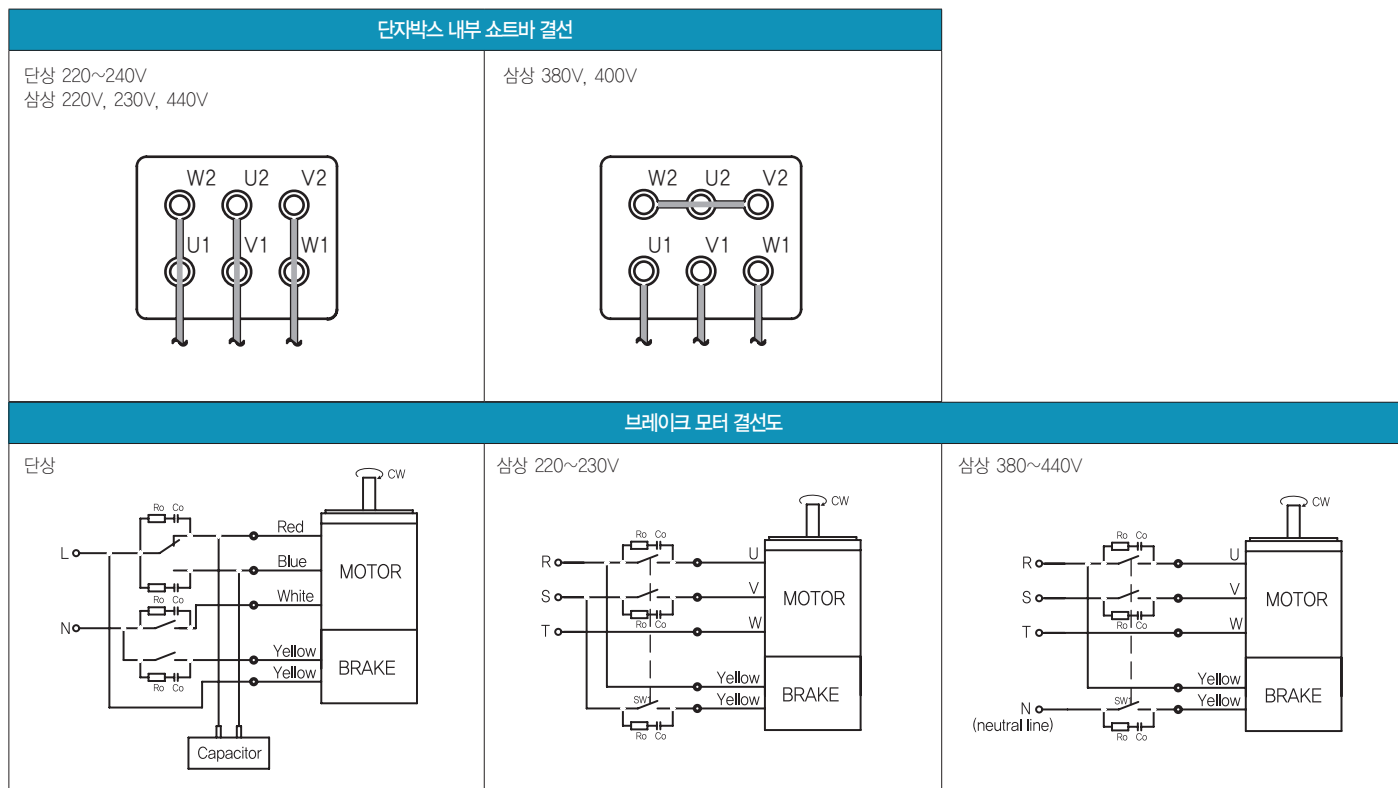

- 회전방향은 모터 축 측에서 본 방향을 나타냅니다.
- CW는 시계방향, CCW는 반시계방향입니다.
- 브레이크 전원은 220V 전용입니다.