

Brake Motor 150W (□90mm)

150W Brake Motor 150W(□90mm)

Brake Motor 150W (□90mm)

Motor Specification

Model 9BDG*-150F□: Gear Type Shaft 9BDD*-150F: D-Cut Type Shaft 9BDK*-150F: Key Type Shaft	Output W	Voltage V	Frequency Hz	Poles	Duty	Starting Torque		Rated Load			Capacitor μF / VAC	
						kgfcm	N.m	Speed r/min	Current A	Torque kgfcm N.m		
9BDGG-150F□	150	3φ220	50	4	Cont.	22.00	2.200	1300	1.00	11.30	1.130	-
			60			19.00	1.900	1550	0.90	9.40	0.940	
9BDGK-150F□	150	3φ380	50	4	Cont.	18.00	1.800	1250	0.46	11.70	1.170	-
			60			15.00	1.500	1500	0.42	9.70	0.970	
		3φ400	50	4	Cont.	19.00	1.900	1250	0.49	11.70	1.170	
			60			16.00	1.600	1500	0.43	9.70	0.970	

1) Enter the phase & voltage code in the place * and enter the model type of attaching Gearbox in the box (□) within the motor model name.

2) All models contain a built-in thermal protector.

3) Gear Type Shaft is for attaching Gearbox and D-Cut & Key Type Shafts are for using motor only.

※ It is not possible to use inverter for three phase 380~440V motor. When inverter is used, the insulation of winding coil becomes hot and may cause damage to the motor.

Max. Permissible Torque at Output Shaft of Gearbox

60Hz

Motor Model	Gearbox Model	Gear Ratio r/min	3	3.6	6	9	12.5	15	18	20	25	30	36	50	60	75	90	100	120	150	180	200	
			600	500	300	200	144	120	100	90	72	60	50	36	30	24	20	18	15	12	10	9	
9BDG□ -150FH	9HBK□BH 9HFK□BH	kgfcm	24.2	29.0	48.3	72.5	90.9	109.1	131.0	131.9	164.9	197.9	237.5	300.0	300.0	300.0	300.0	300.0	300.0	300.0	300.0	300.0	300.0
		N.m	2.37	2.84	4.73	7.10	8.91	10.69	12.83	12.93	16.16	19.39	23.27	29.40	29.40	29.40	29.40	29.40	29.40	29.40	29.40	29.40	29.40

Motor Model	Gearbox Model	Gear Ratio r/min	7.5	10	15	20	25	30	40	50	60	80	100
			240	180	120	90	72	60	45	36	30	22.5	18
9BDG□ -150FWH	9WHD□-030 9WHD□-040	kgfcm	61.1	78.6	110.6	139.7	160.1	186.2	183.7	173.5	163.3	132.7	-
		N.m	5.99	7.70	10.84	13.69	15.68	18.25	18.00	17.00	16.00	13.00	-
		kgfcm	-	-	-	-	-	-	-	230.0	255.0	295.0	270.0
		N.m	-	-	-	-	-	-	-	22.55	25.00	28.92	26.47

50Hz

Motor Model	Gearbox Model	Gear Ratio r/min	3	3.6	6	9	12.5	15	18	20	25	30	36	50	60	75	90	100	120	150	180	200	
			500	417	250	167	120	100	83	75	60	50	42	30	25	20	17	15	13	10	8	7.5	
9BDG□ -150FH	9HBK□BH 9HFK□BH	kgfcm	28.1	33.8	56.3	84.4	105.9	127.1	152.6	153.7	192.1	230.5	276.6	300.0	300.0	300.0	300.0	300.0	300.0	300.0	300.0	300.0	300.0
		N.m	2.76	3.31	5.51	8.27	10.38	12.46	14.95	15.06	18.83	22.59	27.11	29.40	29.40	29.40	29.40	29.40	29.40	29.40	29.40	29.40	29.40

Motor Model	Gearbox Model	Gear Ratio r/min	7.5	10	15	20	25	30	40	50	60	80	100
			200	150	100	75	60	50	37.5	30	25	18.75	15
9BDG□ -150FWH	9WHD□-030 9WHD□-040	kgfcm	71.2	91.5	128.8	162.7	186.5	204.1	183.7	173.5	163.3	132.7	-
		N.m	6.98	8.97	12.62	15.95	18.28	20.00	18.00	17.00	16.00	13.00	-
		kgfcm	-	-	-	-	-	-	-	275.0	305.0	295.0	270.0
		N.m	-	-	-	-	-	-	-	26.96	29.90	28.92	26.47

1) Enter the phase & voltage code in the box (□) within the motor model name.

2) Enter the gear ratio in the box (□) within the Gearbox model name.

3) A colored background indicates gear shaft rotation in the same direction as the motor shaft; a white background indicates rotation in the opposite direction.

4) The rotating speed is calculated by dividing the motor's synchronous speed (50Hz: 1,500r/min, 60Hz: 1,800r/min) by the gear ratio.

The actual speed is 2~20% less than the displayed value, depending on the size of the load.

B AC Motors

Brake Motor 150W (□90mm)

Dimensions

MOTOR ONLY

- MOTOR MODEL:
9BDD□-150F (GENERAL FAN)

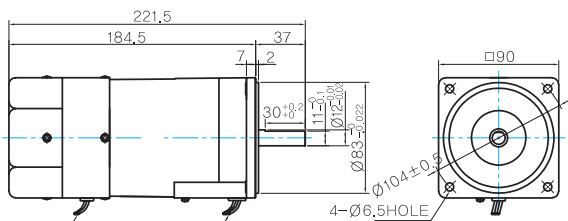

LEAD WIRE(Yellow) 300mm
UL STYLE NO,3398 AWG NO,22
380V OVER NO,3613 AWG NO,22

LEAD WIRE 300mm
UL STYLE NO,3271 AWG NO,22

MOTOR OUTPUT SHAFT

MODEL	SPEC
D-CUT TYPE	
9BDD□-150F	
KEY TYPE	
9BDK□-150F	

KEY SPEC

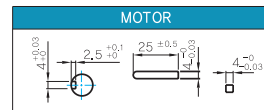

INTER-DECIMAL GEARBOX

- MODEL:
9XD10□□

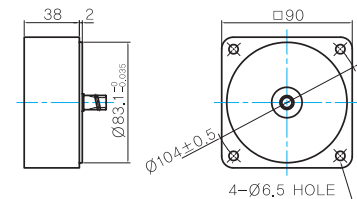

GEARED MOTOR

H TYPE GEARBOX

- MOTOR MODEL:
9BDG□-150FH (GENERAL FAN)

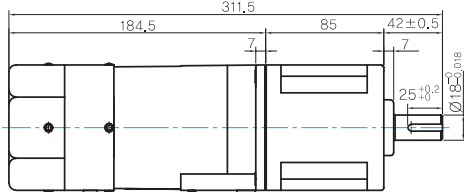

LEAD WIRE(Yellow) 300mm
UL STYLE NO,3398 AWG NO,22
380V OVER NO,3398 AWG NO,22

LEAD WIRE 300mm
UL STYLE NO,3271 AWG NO,22

- GEARBOX MODEL:
9HBK□BH

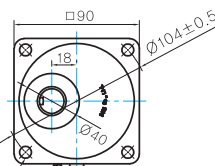

- GEARBOX MODEL:
9HFK□BH

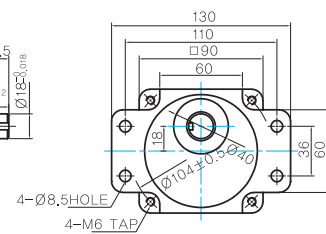
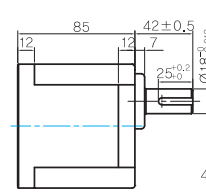

GEARBOX OUTPUT SHAFT

MODEL	SPEC
KEY TYPE	
9HBK□BH	
9HFK□BH	

KEY SPEC

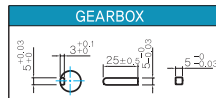

WH TYPE GEARBOX

- MOTOR MODEL:
9BDG□-150FWH (GENERAL FAN)

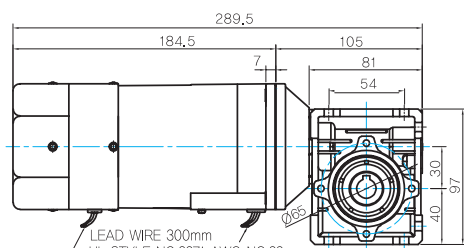

LEAD WIRE 300mm
UL STYLE NO,3271 AWG NO,22

LEAD WIRE(Yellow) 300mm
UL STYLE NO,3398 AWG NO,22
380V OVER NO,3613 AWG NO,22

- GEARBOX MODEL:
9WHD□-030

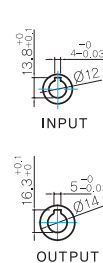
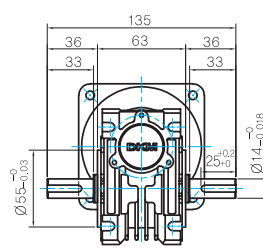

- SHAFT(Unidirectional, Bi-directional)

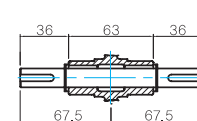
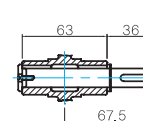

FLANGE

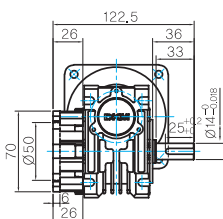
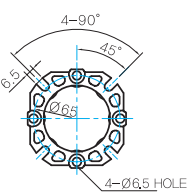

KEY SPEC

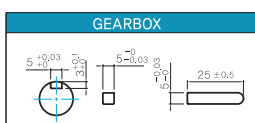

● MOTOR MODEL:
9IDG□-150FWH (GENERAL FAN)

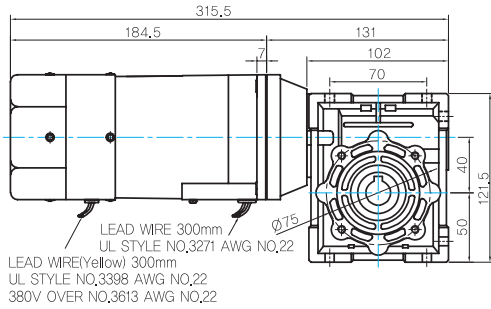

● GEARBOX MODEL:
9WHD□-040

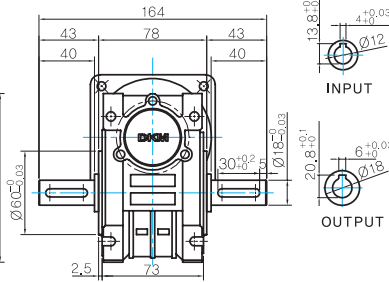

● SHAFT (Unidirectional, Bi-directional)

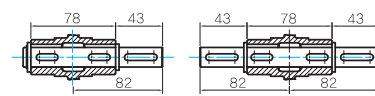

● FLANGE

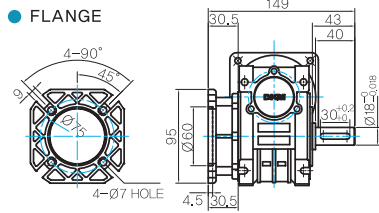

● KEY SPEC

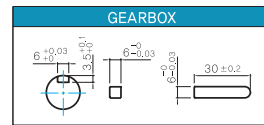

● WEIGHT

PART	WEIGHT (Kg)	
MOTOR	3,5	
GEAR BOX	9HB(F)K3BH ~ 9HB(F)K9BH	1,45
	9HB(F)K12.5BH ~ 9HB(F)K18BH	1,5
	9HB(F)K20BH ~ 9HB(F)K60BH	1,7
	9HB(F)K75BH ~ 9HB(F)K180BH	1,8
	9WHD□-030	1,13
9WHD□-040	2,2	
9XD10□	0,5	

* The output flange and shafts are sold separately.

Connection Diagrams

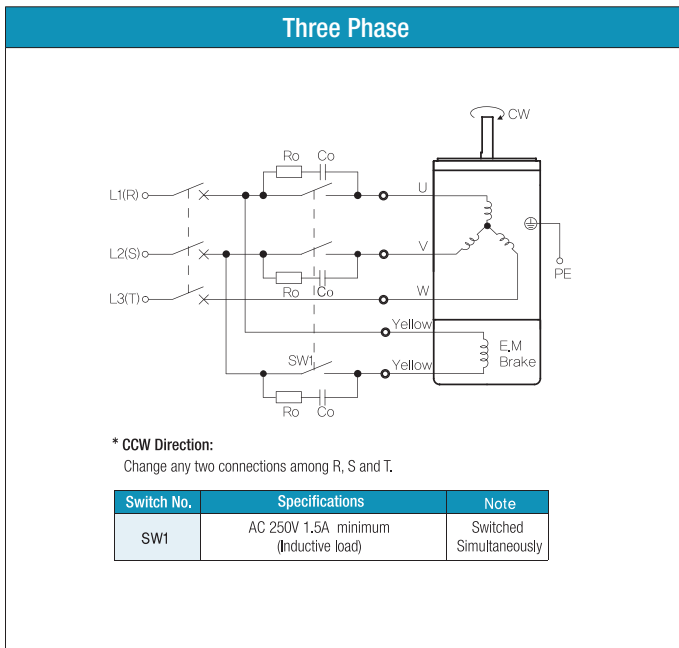

Motor Images



- 1) The direction of motor rotation is as viewed from the shaft end of the motor.
- 2) CW represents the clockwise direction, while CCW represents the counterclockwise direction.
- 3) SW1 operates both motor and electromagnetic brake action.
- 4) The electromagnetic brake will be released and the motor will rotate when SW1 is switched simultaneously to ON. When SW1 is switched simultaneously to OFF, the motor stops immediately with the electromagnetic brake and holds the load.
- 5) If you wish to release the brake while the motor is stopped, apply voltage between the two brake lead wires (yellow).
- 6) Ro and Co indicate CR circuit for surge suppression. [Ro=5~200Ω, Co=0.1~0.2μF, 200WV (400WV)]