

B AC Motors

Induction Motor 6W(□70mm)

6W

Induction Motor
6W(□70mm)

Motor Specification

Model		Output W	Voltage V	Frequency Hz	Poles	Duty	Starting Torque		Rated Load			Capacitor μF / VAC	
Lead Wire Type	Terminal Box Type						kgfcm	N.m	Speed r/min	Current A	Torque kgfcm N.m		
7IDG□-6G(-T): Gear Type Shaft 7IDD□-6(-T): D-Cut Type Shaft													
7IDGA-6G	7IDGA-6G-T	6	1∅110	60	4	Cont.	0.53	0.053	1600	0.30	0.41	0.041	2.5 / 250
7IDGD-6G	7IDGD-6G-T	6	1∅220	60	4	Cont.	0.54	0.054	1550	0.16	0.55	0.055	0.7 / 450
7IDGE-6G	7IDGE-6G-T	6	1∅220	50	4	Cont.	0.57	0.057	1250	0.13	0.60	0.060	0.7 / 450
			1∅240				0.67	0.067		0.15	0.70	0.070	

- 1) Enter the phase & voltage code in the box (□) within the motor model name.
- 2) All models contain a built-in thermal protector.
- 3) Gear Type Shaft is for attaching Gearbox and D-Cut Type Shaft is for using motor only.

Max. Permissible Torque at Output Shaft of Gearbox

60Hz

Motor Model	Gearbox Model	Gear Ratio	3	3.6	6	7.5	9	12.5	15	18	25	30	36	50	60	75	90	100	120	150	180
			r/min	600	500	300	240	200	144	120	100	72	60	50	36	30	24	20	18	15	12
7IDG□-6G	7GBK□BMH	kgfcm	1.4	1.6	2.7	3.4	4.1	5.7	6.8	8.2	10.3	12.4	13.5	18.7	22.4	28.1	33.7	37.4	44.9	50.0	50.0
		N.m	0.13	0.16	0.27	0.34	0.40	0.56	0.67	0.81	1.01	1.21	1.32	1.83	2.20	2.75	3.30	3.67	4.40	4.9	4.9

50Hz

Motor Model	Gearbox Model	Gear Ratio	3	3.6	6	7.5	9	12.5	15	18	25	30	36	50	60	75	90	100	120	150	180
			r/min	500	416	250	200	166	120	100	83	60	50	41	30	25	20	16	15	12.5	10
7IDG□-6G	7GBK□BMH	kgfcm	1.7	2.1	3.5	4.4	5.2	7.3	8.7	10.5	13.1	15.8	17.1	23.8	28.6	35.7	42.8	47.6	50.0	50.0	50.0
		N.m	0.171	0.20	0.34	0.43	0.51	0.71	0.85	1.02	1.29	1.54	1.68	2.33	2.80	3.50	4.20	4.66	4.9	4.9	4.9

- 1) Enter the phase & voltage code in the box (□) within the motor model name.
- 2) Enter the gear ratio in the box (□) within the Gearbox model name.
- 3) A colored background indicates gear shaft rotation in the same direction as the motor shaft; a white background indicates rotation in the opposite direction.
- 4) The rotating speed is calculated by dividing the motor's synchronous speed (50Hz: 1,500r/min, 60Hz: 1,800r/min) by the gear ratio. The actual speed is 2~20% less than the displayed value, depending on the size of the load.

Motor Images

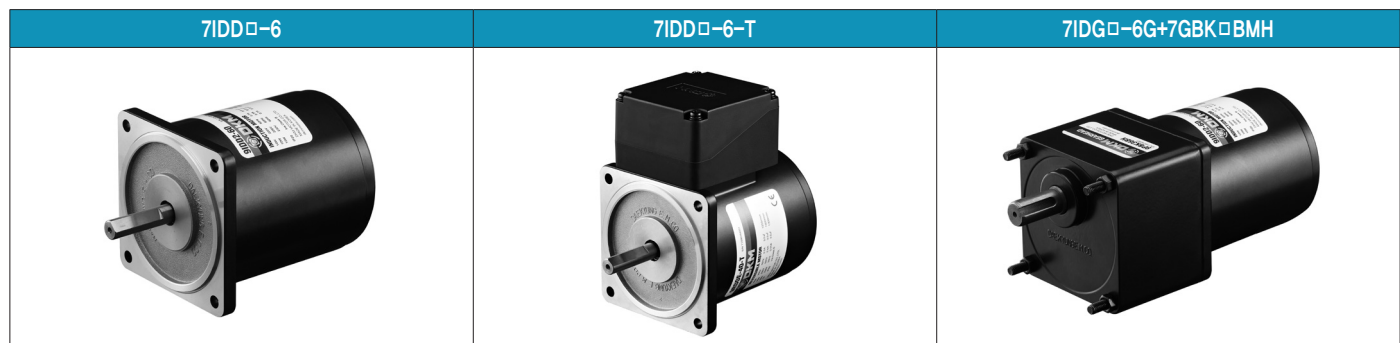

Dimensions

MOTOR ONLY

- MOTOR MODEL: 7IDD□-6(-T) (NO FAN)

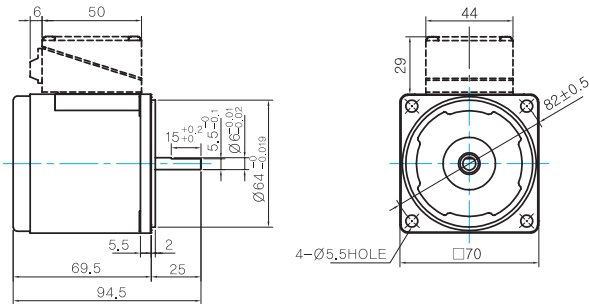

MOTOR OUTPUT SHAFT

MODEL	SPEC
D-CUT TYPE	

GEARED MOTOR

G TYPE GEARBOX

- MOTOR MODEL: 7IDG□-6G (NO FAN)

- GEARBOX MODEL: 7GBK□BMH

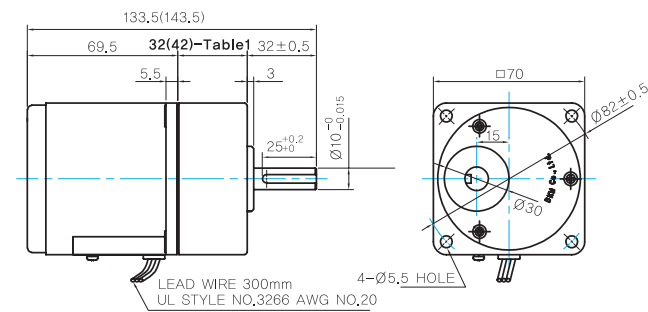

GEARBOX OUTPUT SHAFT

MODEL	SPEC
KEY TYPE	

KEY SPEC

GEARBOX

WEIGHT

PART	WEIGHT(Kg)
MOTOR	0,84
GEAR BOX	
7GBK3BMH - 7GBK18BMH	0,36
7GBK25BMH - 7GBK30BMH	0,44
7GBK36BMH - 7GBK180BMH	0,5

32(42)-Table1

SIZE(mm)	GEAR RATIO
32	7GBK3BMH - 7GBK18BMH
42	7GBK25BMH - 7GBK180BMH

Connection Diagrams

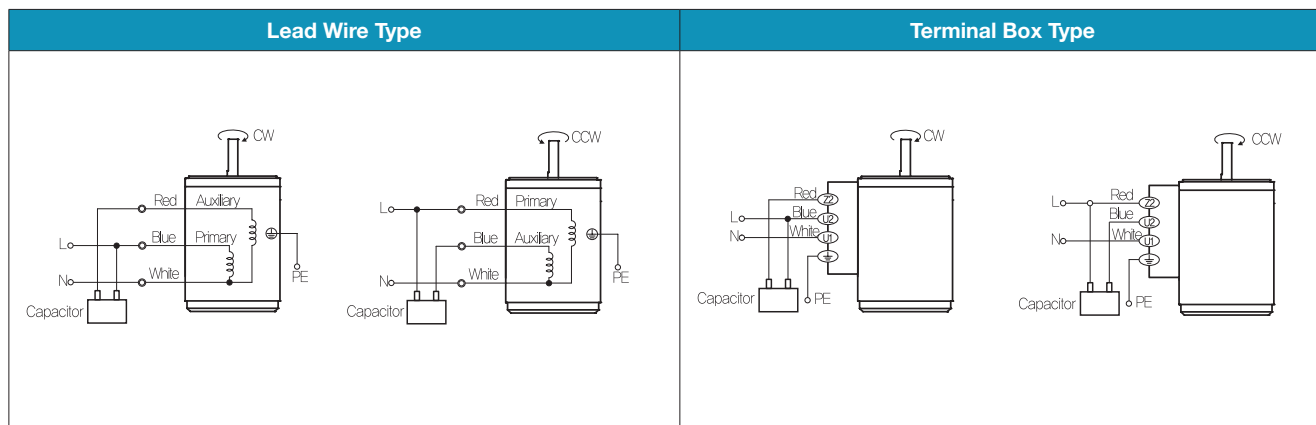

- The direction of motor rotation is as viewed from the shaft end of the motor. 2) CW represents the clockwise direction, while CCW represents the counterclockwise direction.
- Change the direction of single phase motor rotation only after bringing the motor to a stop. If an attempt is made to change the direction of rotation while the motor is rotating, the motor may ignore the reversing command or change its direction after some delay.