

Operation/Parameter Setting Procedure

■ Operation setting procedure

After wiring, set as follows.

① Input AC power(Terminal CN1 #1, #2)

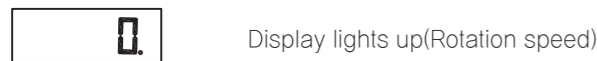

② Operation switch→RUN

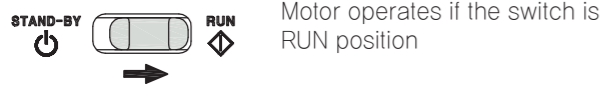

③ Operation switch→STOP



④ Rotation direction setting

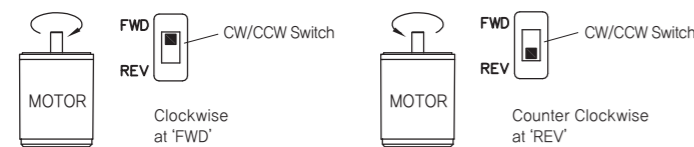

※ Caution
Please change rotation direction after the motor completely stops.

⑤ Rotation speed setting

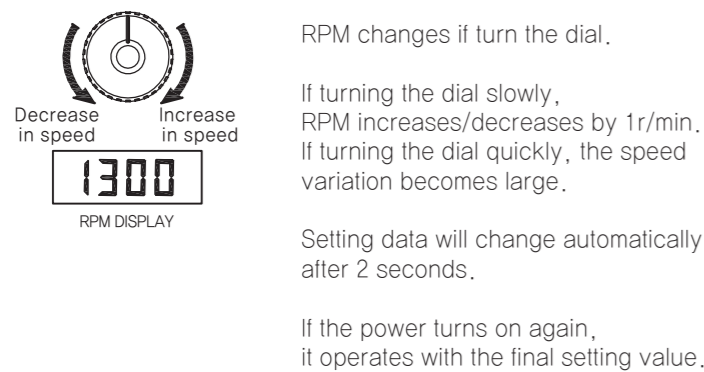

※ Please refer to 'CW/CCW signal connection' in the manual if operating RUN/STOP externally.

Display/ Setting

■ Entire Transition Diagram

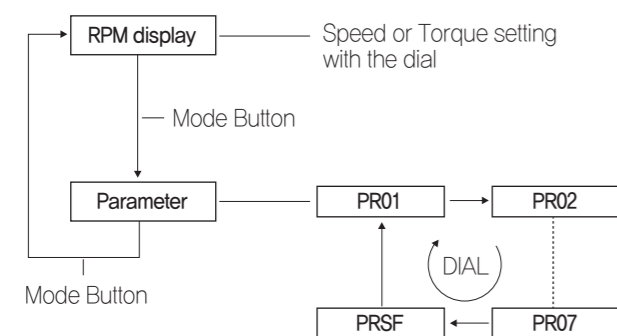

※Speed Control P, I gain
- Parameter to determine the responsibility of speed control.
- Vibration and hunting phenomenon occurs if the value is too large.

■ Parameter setting procedure

After wiring, set as follows.

① Input AC power

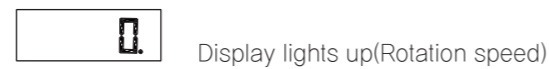

② Select parameter mode

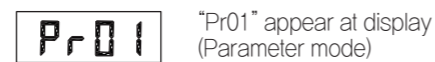
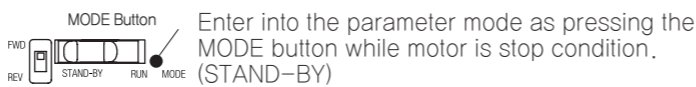

③ Parameter Data

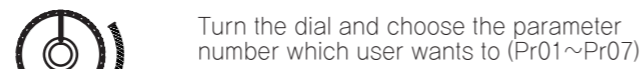

④ Change Parameter Data

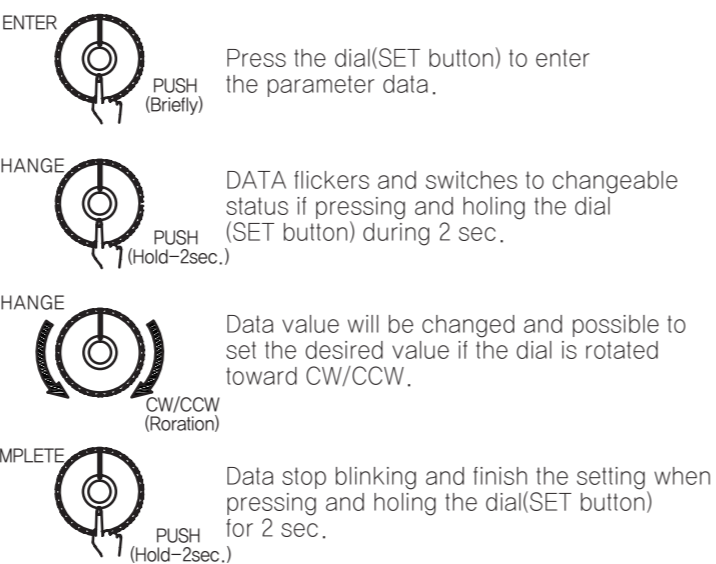

⑤ Operation Mode



■ Parameter Contents

Parameter NO.	Display	Function	Range	Standard Value	Remark
1	Pr01	Acceleration Time	0~15.0	0.1	Time(second) to reach the set speed
2	Pr02	Rotation Direction	0, 1	0	0 : Clockwise 1 : Counterclockwise
3	Pr03	Gear Ratio	1~999	1.0	Input gear ratio
4	Pr04	Control Mode	0, 1	0	0: Speed Control 1: Torque Control
5	Pr05	P Gain	0~255	100	
6	Pr06	I Gain	0~255	50	
7	Pr07	Parameter Reset	-	0	Reset when pressing and holding the SET button
SF	PrSF	Software Version	-	-	Display the software version

DKM DIGITAL SPEED TORQUE CONTROLLER

FX3000 manual

We appreciate you for purchasing products of DKM Motor co., Ltd. Before using the product you have purchased, check to make sure that it is exactly what you ordered. Then, please use it following the instructions below.



DKM Motor Co., Ltd.

Head Office / Factory
292, Yeomjeon-ro, Michuhol-gu,
Incheon Republic of Korea 22117
Tel. +82.32.574.7788 Fax. +82.32.578.7787
www.dkmmotor.com



SAFETY INFORMATION

Alerts declared in the manual are classified to Danger, Warning and Caution by their criticality

▲ DANGER	DANGER indicates imminently hazardous situation which, if not avoided, will result in death or serious injury.
▲ WARNING	WARNING indicates a potentially hazardous situation which, if not avoided, could result in death or serious injury.
▲ CAUTION	CAUTION indicates a potentially hazardous situation which, if not avoided, may result in minor or moderate injury.

▲ DANGER

There is a danger of occurred shock in the input/output terminals so please never let your body or conductive substance is touched.

▲ WARNING

- Do not put around the explosive atmosphere, gas to be burnt, corrosive air, the location to be wet and combustibles. If not, there will be the electric shock and the fire.
- Installation, connection, operation, maintenance and diagnostic operation should be carried out by the person who has expertise.
- Use the product after turning off the power. It may cause an electric shock.
- The power cable and the lead wire should not be bent, pulled and inserted by force. If not, the electric shock and the fire may occur.
- In case of the motor and controlling unit are attached to the machine, never touch with hand or connect with the earth. If not, the electric shock may take place.
- Within the 30 seconds after the power off, do not touch the output terminal of the controlling unit. If not, the electric shock may occur because of the residual volts.

▲ CAUTION

- The motor and the controlling unit should be used only by the designated compounding. If not, the fire may occur.
- Do not operate with the wet hands. The electric shock may occur.
- In case of moving, do not catch the output shaft, connecting part or the lead wire. There may be the injury by the drop.
- The motor should be used after it is fixed tightly. If not, the injury and/or the damage of the unit may occur.
- Do not touch the rotating part (output shaft, cooling fan) in running. It could be cause of injury.
- If there are abnormal cases, turn off the power at once. If not, there will be the electric shock, injury and the damage.
- Do not touch the motor for a while, if the motor's surface temperature exceeds 90°C.
- Be sure to set the switch STOP before connecting to the power.
- Make sure to check the rotating direction before connecting the machine. If not, the injury and/or the damage of the unit may occur.
- Use products only according to the specification of motor and controlling unit. If not, there will be dangerous fire, electric shock, injury and/or damage of the unit.
- Make sure to install the overload device because the protection device is not attached to the motor. It is desirable to install other protection devices other than overload protection device to prevent fire.

SPECIAL FEATURES

- Possible to control speed and torque.
- Possible to control the speed and torque of the motor simply by connecting motor and control unit with connector and inputting the AC terminal to the power source.

BEFORE USE

- Display the current rotation speed(r/min) and torque(%).
- Possible to control speed and torque easily with the front panel dial.
- Possible to operate various functions by setting the parameter.
- Check specifications which you ordered such as voltage, output and so on.
- Make sure a motor item whether the motor can be applicable with DKM controller.
- Avoid the place in vibration, deep Impact, lots of dusty, inflammable gas and corrosive gas.
- Use ambient temperature(-10 °C ~ 40 °C) and ambient humidity (85% maximum and avoid direct sunlight, moisture and greasy place.
- Install motor and controller as closely as possible. (within 2m)

CONTROLLER CODING SYSTEM

FX3000	006	S
Controller Model	OUTPUT	TYPE
	003: 3W 030: 30W 006: 6W 040: 40W 010: 10W 060: 60W 015: 15W 090: 90W 020: 20W 120: 120W 025: 25W 180: 180W	S: Speed Motor T: Torque Motor

- Initial setting mode is speed control. Please change '0'(speed mode) to '1' (torque motor) after selecting parameter 'Pr04'(control mode) if using torque motor. Regarding changing method, please refer to 'Parameter setting procedure' and 'Display/Setting' in the manual.

Specifications

Model Name	FX3000-□□
Rated Voltage	1Ø AC 220~240V 50/60Hz ±10%
Allowable Current	Below 6 A
Control Function	Speed Control, Torque Control
Control System	Phase Control
Setting Range	Speed Control 50Hz : 90~1400r/min 60Hz : 90~1700r/min
	Torque Control 0 ~ 100 %
Speed Setting	Setting by Volume
Speed Variation	±5%(Standard Value)
Motor Output	3W~180W
Ambient Temperature	-10°C ~ 55°C
Ambient Humidity	35 ~ 85%RH (Without condensation)
Insulation Resistance	Over DC 500V 100MΩ (between power supply and external terminal)
Dielectric Strength	AC 1500V 1minute (between power supply and external terminal)

How to mount controller

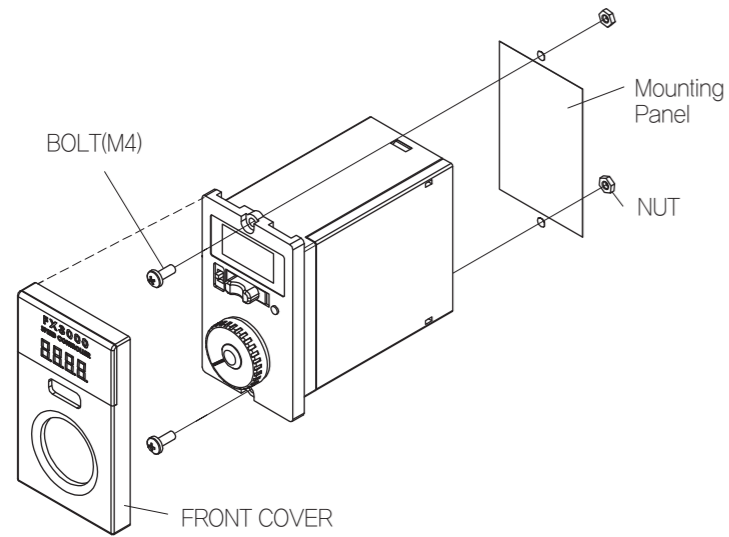

Mounting Panel Dimension

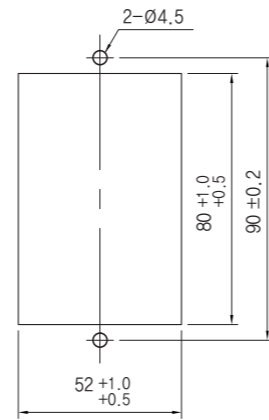

How to install

- Process the hole on the mounting panel to attach the controller.
- Fix the mounting panel and controller body with M4 bolt and nut.
- Cover the front cover after controller installation, operation and parameter setting.

Caution

- Install without gap between the controller and the mounting panel.
- The screw head fixed with controller should be below 3mm, if over 3mm, front cover can't be amounted.

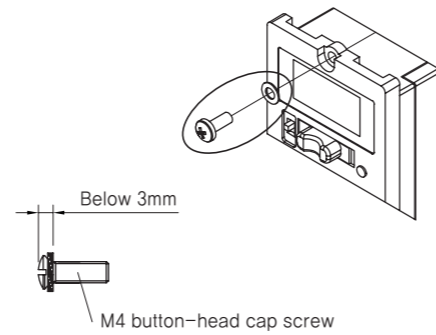

Each part name and Dimension

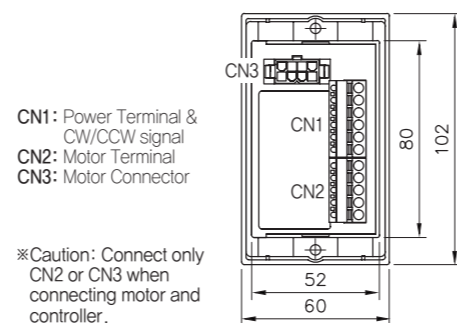
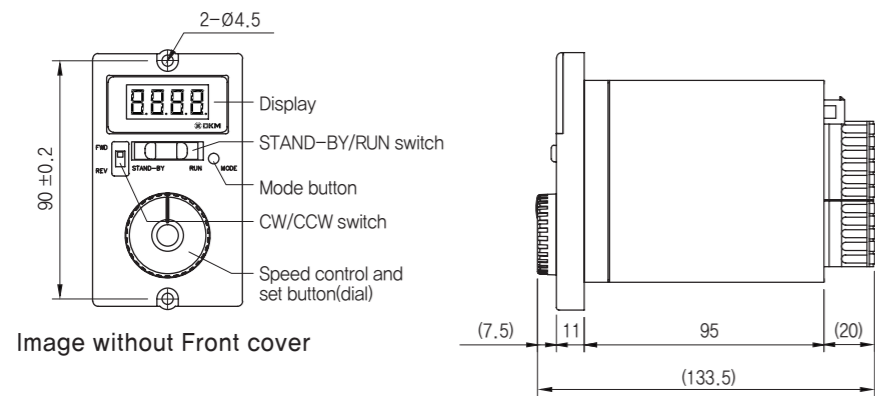

※ Caution: Connect only CN2 or CN3 when connecting motor and controller.

Connection

1. Controller Power Connection

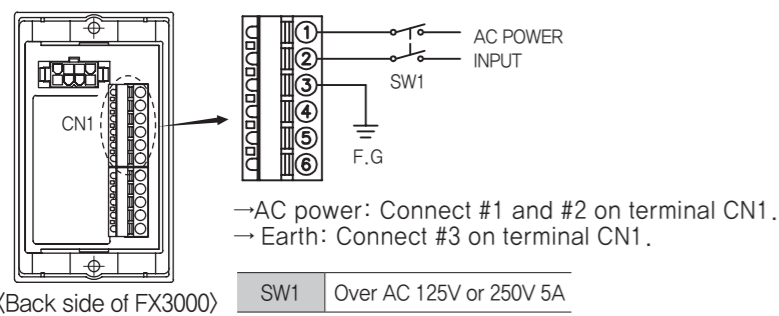

SW1 Over AC 125V or 250V 5A

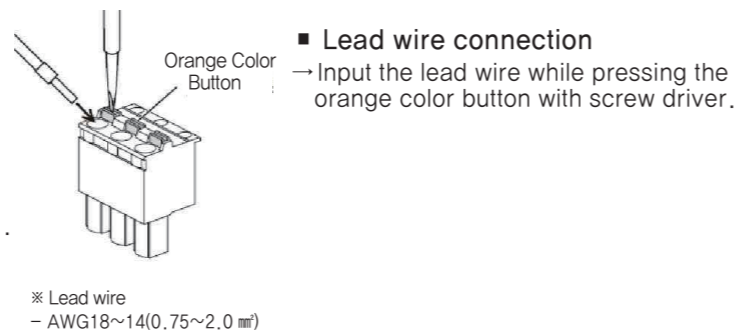

Lead wire connection

→ Input the lead wire while pressing the orange color button with screw driver.

2. CW/CCW Signal connection

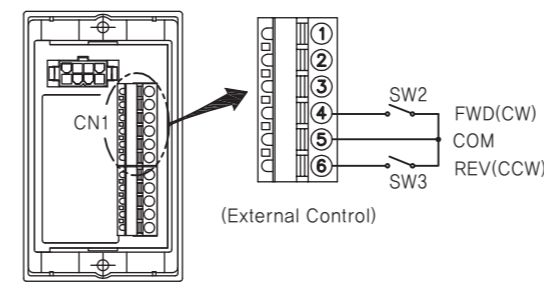

* In case of RUN/ STOP operation externally, please make sure that switch position should be on STAND-BY and connect to terminal CN1 #4, #5, #6.

SW2	SW3	Motor shaft
ON	OFF	Rotate to FWD
OFF	ON	Rotate to REV
OFF	OFF	Stop

※ When using the front panel 'STAND-BY/RUN switch' or 'forward/reverse switch', Do not connect terminal 'CN1' #4, #5, #6 in the real panel. (terminal 'CN1' #4, #5, #6: Connect only for external operation/stop.)

3. Connection of motor and controller

1) Wiring Diagram of Speed Control Motor or Torque Motor

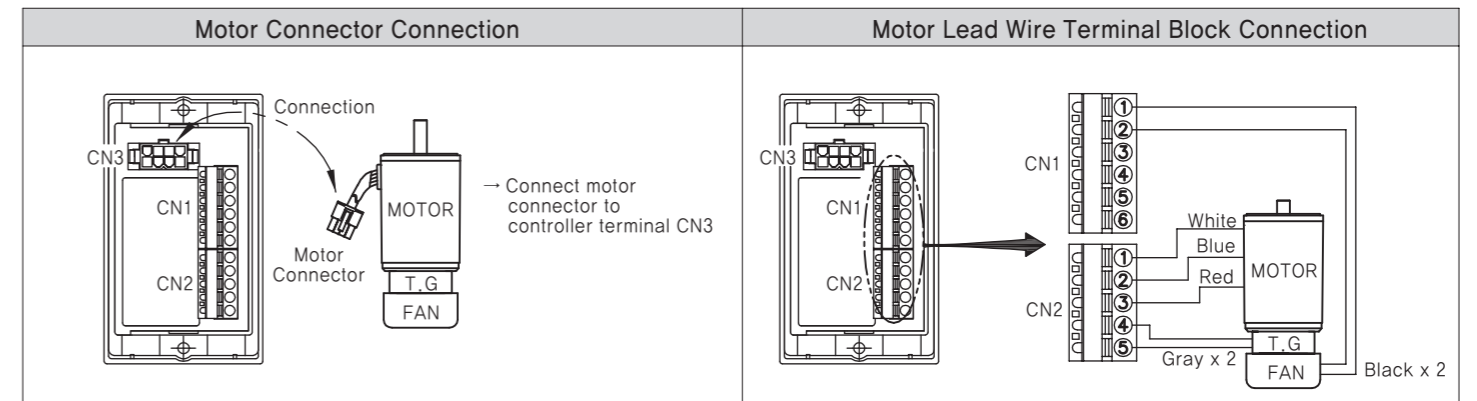

※ Regarding terminal CN1 wiring, please refer to the 'controller power connection' or 'CW/CCW signal connection' in the manual.
※ According to the motor type, TG wire(gray*2) and powerful fan wire(black*2) may not be in.

2) SPEED CONTROL BRAKE MOTOR Connection Diagram

Below diagram is the Brake wiring. Regarding other motors, please refer to the speed control motor or torque motor connection.

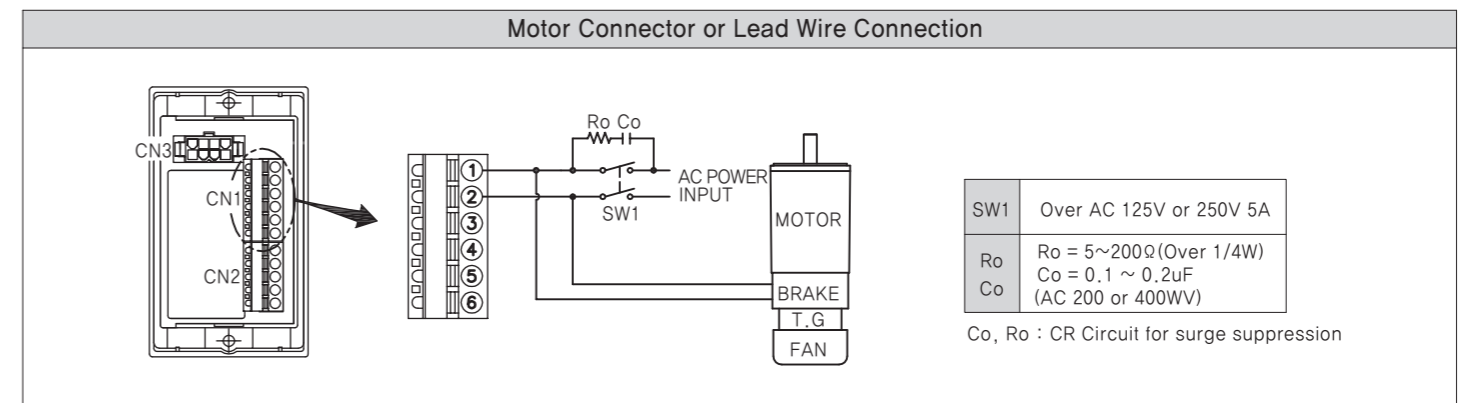

3) SPEED CONTROL CLUTCH & BRAKE MOTOR Connection Diagram

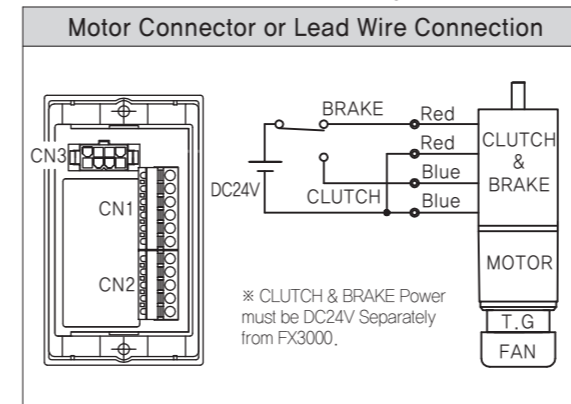

4) Connection Diagram for other brand motor

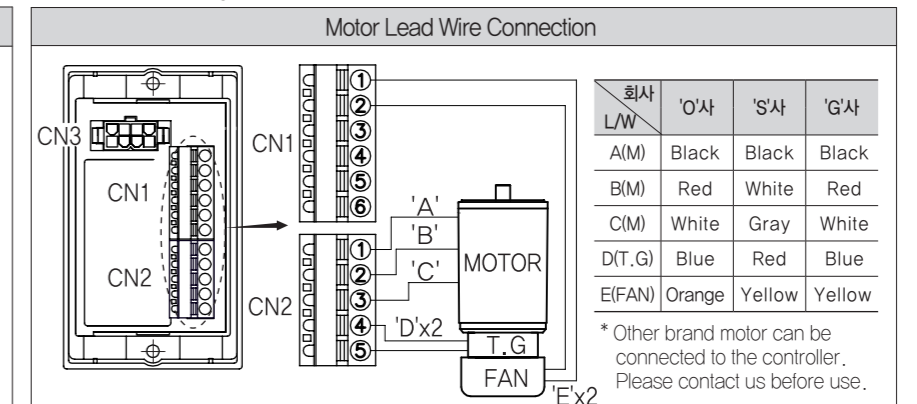

→ This diagram is the Clutch&Brake Connection. Regarding other type motors, please refer to the speed control motor or torque motor wiring.

※ Depending on the motor type and specifications, T.G and powerful fan could not be in.
※ Do not connect to CN3 when connecting other brand motor.