

1 2 3 4 5 6 7 8

A
B
C
D
E
F

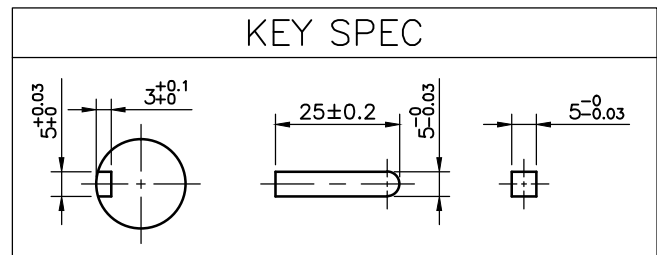
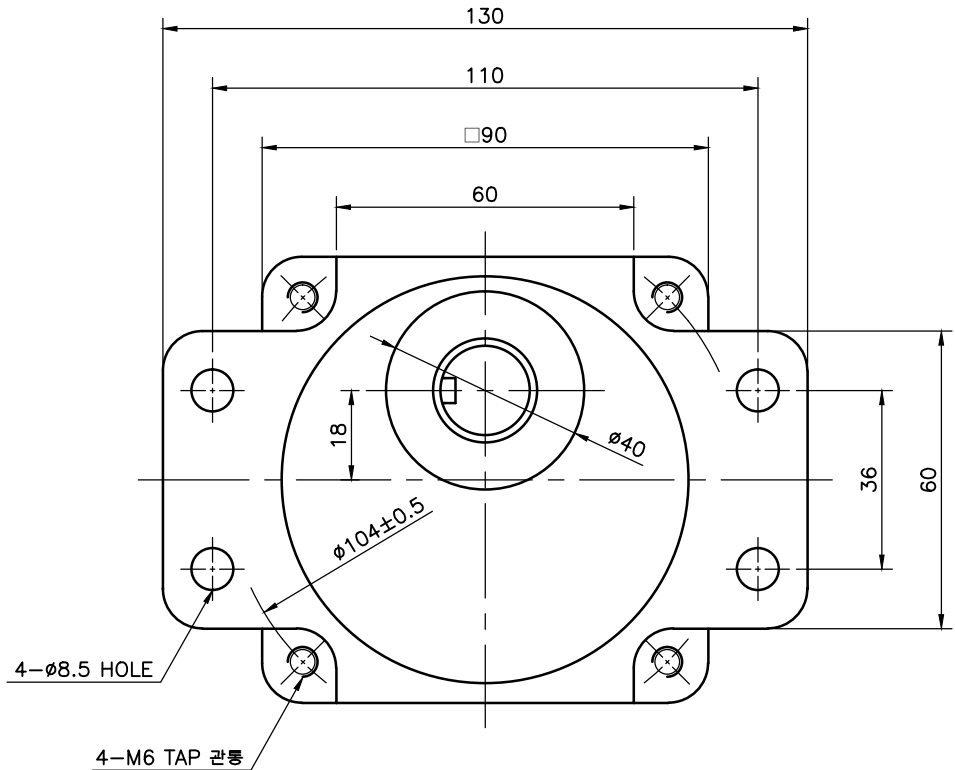
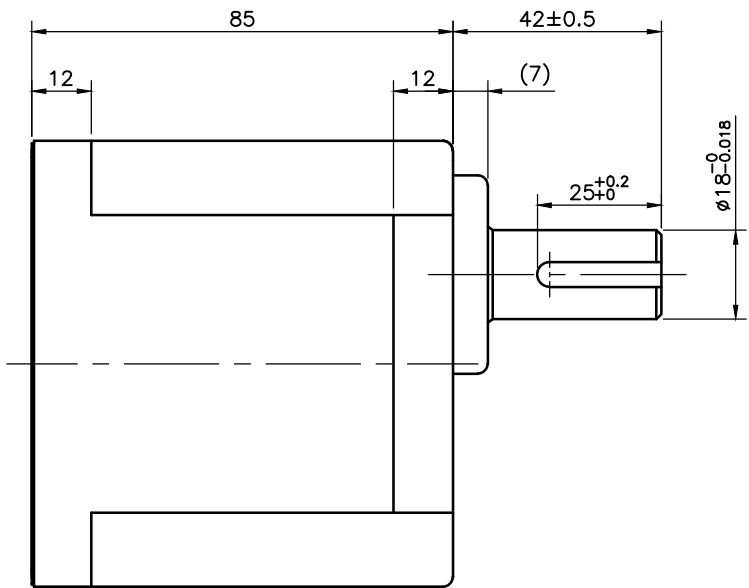

REV.	DESCRIPTION	DATE	CHECK
1		2	

일반공차		1	NOMENCLATURE			MATERIAL	LOT	REMARKS
0.5~6	±0.05	NO.	UNIT : mm	APPROV	DESIGN	DRAWN	Q'TY	9HFK□BH
6~30	±0.1	N S					TITLE	
30~120	±0.15							
120~315	±0.2	DATE					SHE.NO.	
315~1000	±0.3						DWG.NO.	
1000~2000	±0.5							