

C DC Motors

DC Motor 120W(□90mm)

120W DC Motor 120W(□90mm)

Motor Specification

Model 9DCP(W)□-120-30: Gear Type Shaft 9DCD□-120-30: D-Cut Type Shaft 9DCK□-120-30: Key Type Shaft	Output W	Voltage V	Starting Current A	Starting Torque		No Load		Rated Load			
				kgfcm	N.m	Current A	Speed r/min	Current A	Speed r/min	Torque kgfcm N.m	
9DCP(W)12-120-30	120	12	96.00	31.00	3.100	4.00	3400	15.00	3000	3.90	0.390
9DCP(W)24-120-30	120	24	64.00	39.00	3.900	1.50	3250	6.80	3000	3.90	0.390
9DCP(W)90-120-30	120	90	18.00	37.00	3.700	0.30	3400	2.00	3000	3.90	0.390

- 1) Enter the phase & voltage code in the in the box (□) within the motor model name.
2) Gear Type Shaft are for attaching Gearbox and D-Cut & Key Type Shafts are for using motor only.

Performance Curve

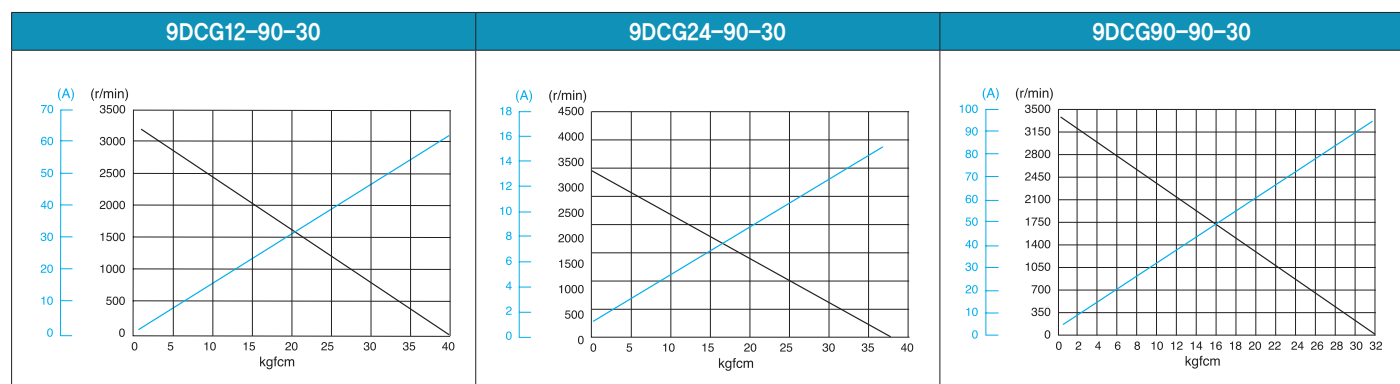

Max. Permissible Torque at Output Shaft of Gearbox

Motor Model	Gearbox Model	Gear Ratio r/min	Gear Ratio																									
			2	3	3.6	5	6	7.5	9	12.5	15	18	20	25	30	36	40	50	60	75	90	100	120	150	180	200		
9DCP□-120-30	9PBK□BH	Rated	kgfcm	6.5	9.7	11.7	16.2	19.4	24.3	29.1	36.6	43.9	52.7	53.0	66.3	79.6	95.5	106.1	132.6	159.1	178.4	200.0	200.0	200.0	200.0	200.0	200.0	
		N.m	0.63	0.95	1.14	1.59	1.90	2.38	2.86	3.58	4.30	5.16	5.20	6.50	7.80	9.36	10.40	12.99	15.59	17.49	19.60	19.60	19.60	19.60	19.60	19.60	19.60	
	9PFK□BH	12V	Starting	kgfcm	51.5	77.2	92.6	128.7	154.4	193.0	200.0	200.0	200.0	200.0	200.0	200.0	200.0	200.0	200.0	200.0	200.0	200.0	200.0	200.0	200.0	200.0	200.0	200.0
		N.m	5.04	7.56	9.08	12.61	15.13	18.91	19.60	19.60	19.60	19.60	19.60	19.60	19.60	19.60	19.60	19.60	19.60	19.60	19.60	19.60	19.60	19.60	19.60	19.60	19.60	
	24V	Starting	kgfcm	64.7	97.1	116.5	161.9	194.2	200.0	200.0	200.0	200.0	200.0	200.0	200.0	200.0	200.0	200.0	200.0	200.0	200.0	200.0	200.0	200.0	200.0	200.0	200.0	200.0
		N.m	6.34	9.52	11.42	15.86	19.03	19.60	19.60	19.60	19.60	19.60	19.60	19.60	19.60	19.60	19.60	19.60	19.60	19.60	19.60	19.60	19.60	19.60	19.60	19.60	19.60	19.60
90V	Starting	kgfcm	61.4	92.1	110.6	153.6	184.3	200.0	200.0	200.0	200.0	200.0	200.0	200.0	200.0	200.0	200.0	200.0	200.0	200.0	200.0	200.0	200.0	200.0	200.0	200.0	200.0	
	N.m	6.02	9.03	10.83	15.05	18.06	19.60	19.60	19.60	19.60	19.60	19.60	19.60	19.60	19.60	19.60	19.60	19.60	19.60	19.60	19.60	19.60	19.60	19.60	19.60	19.60	19.60	

Motor Model	Gearbox Model	Gear Ratio		Gear Ratio									
		r/min		10	12	15	18	25	30	36	50	60	
9DCW□-120-30	9WD□BL/□BR/□BRL	Rated	kgfcm	32.0	37.4	45.0	51.9	68.3	77.2	89.9	117.0	122.4	
			N.m	3.13	3.67	4.41	5.09	6.69	7.57	8.81	11.47	12.00	
		12V	Starting	kgfcm	163.3	153.1	163.3	153.1	142.9	163.3	153.1	142.9	122.4
			N.m	16.00	15.00	16.00	15.00	14.00	16.00	15.00	14.00	12.00	
		24V	Starting	kgfcm	163.3	153.1	163.3	153.1	142.9	163.3	153.1	142.9	122.4
			N.m	16.00	15.00	16.00	15.00	14.00	16.00	15.00	14.00	12.00	
90V	Starting	kgfcm	163.3	153.1	163.3	153.1	142.9	163.3	153.1	142.9	122.4		
	N.m	16.00	15.00	16.00	15.00	14.00	16.00	15.00	14.00	12.00			

- 1) Enter the phase & voltage code in the box (□) within the motor model name.
2) Enter the gear ratio in the box (□) within the Gearbox model name.
3) A colored background indicates gear shaft rotation in the same direction as the motor shaft; a white background indicates rotation in the opposite direction.
4) The rotating speed is calculated by dividing the motor's synchronous speed (50Hz: 1,500r/min, 60Hz: 1,800r/min) by the gear ratio.
The actual speed is 2~20% less than the displayed value, depending on the size of the load.

Dimensions

MOTOR ONLY

- MOTOR MODEL: 9DCD□-120-30

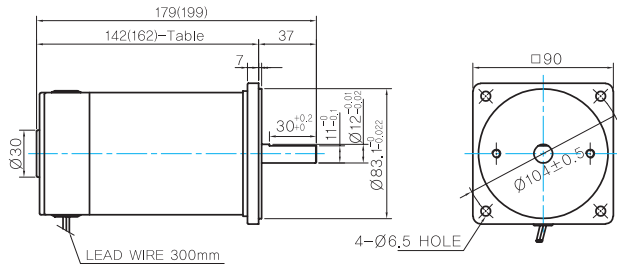

MOTOR OUTPUT SHAFT

MODEL	SPEC
D-CUT TYPE	36,5 30±0.03 11±0.03 Ø12±0.01
9DCD□-120-30	
KEY TYPE	36,5 25±0.03 Ø12±0.01
9DCK□-120-30	

KEY SPEC

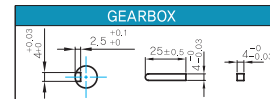

INTER-DECIMAL GEARBOX

- MODEL: 9XD10□□

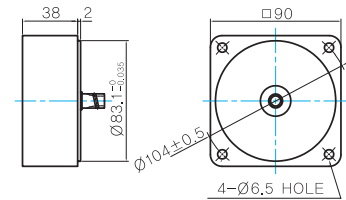

142(162)-Table1

SIZE(mm)	MOTOR VOLTAGE
142	24V,90V
162	12V

GEARED MOTOR

P TYPE GEARBOX

- MOTOR MODEL: 9DCP□-120-30

- GEARBOX MODEL: 9PBK□BH

- GEARBOX MODEL: 9PFK□BH

GEARBOX OUTPUT SHAFT

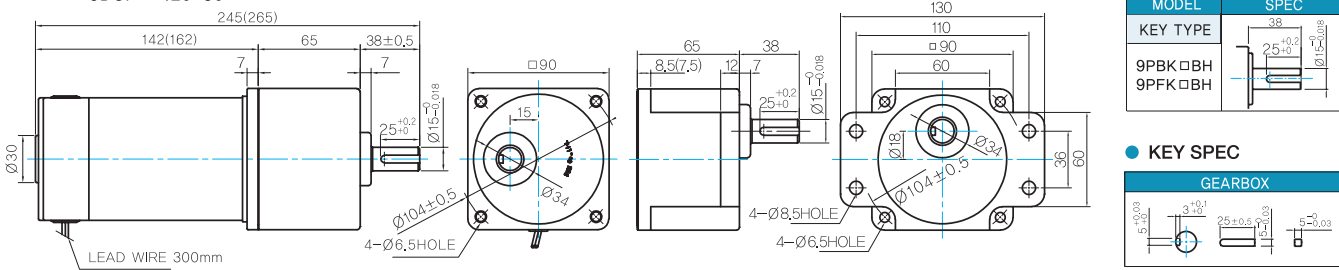

MODEL	SPEC
KEY TYPE	38 38 25±0.2 Ø15±0.015
9PBK□BH	
9PFK□BH	

KEY SPEC

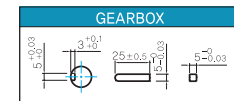

W TYPE GEARBOX

- MOTOR MODEL: 9DCW□-120-30

- GEARBOX MODEL: 9WD□BL/BR/BRL

KEY SPEC

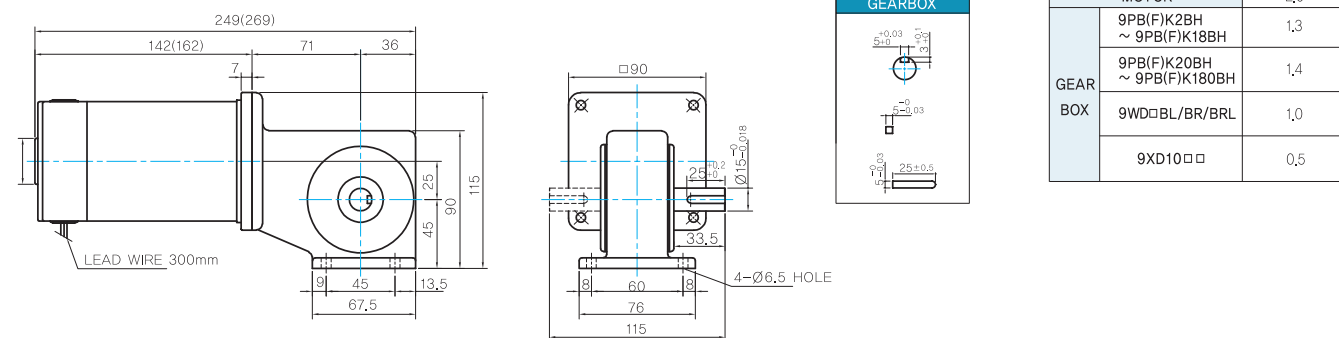

GEARBOX

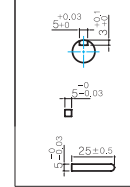

WEIGHT

PART	WEIGHT(Kg)	
MOTOR	2,0	
GEAR BOX	9PB(F)K2BH ~ 9PB(F)K18BH	1,3
	9PB(F)K20BH ~ 9PB(F)K180BH	1,4
	9WD□BL/BR/BRL	1,0
	9XD10□□	0,5

Motor Images

