

# B AC Motors

## Induction Motor 6W(□60mm)

# 6W

Induction Motor  
6W(□60mm)

### Motor Specification

Model		Output	Voltage	Frequency	Poles	Duty	Starting Torque		Rated Load			Capacitor	
Lead Wire Type	Terminal Box Type						kgfcm	N.m	Speed	Current	Torque		μF / VAC
6IDG□-6G(-T): Gear Type Shaft 6IDD□-6(-T): D-Cut Type Shaft		W	V	Hz					r/min	A	kgfcm	N.m	
6IDGA-6G	6IDGA-6G-T	6	1∅110	60	4	Cont.	0.42	0.042	1500	0.20	0.42	0.042	2.5 / 250
6IDGD-6G	6IDGD-6G-T	6	1∅220	60	4	Cont.	0.56	0.056	1550	0.10	0.42	0.042	0.7 / 450
6IDGE-6G	6IDGE-6G-T	6	1∅220	50	4	Cont.	0.42	0.042	1200	0.09	0.43	0.043	0.6 / 450
			1∅240				0.50	0.050		0.10	0.47	0.074	

- 1) Enter the phase & voltage code in the box (□) within the motor model name.
- 2) This model is impedance protected type.
- 3) Gear Type Shaft is for attaching Gearbox and D-Cut Type Shaft is for using motor only.

### Max. Permissible Torque at Output Shaft of Gearbox

#### 60Hz

Motor Model	Gearbox Model	Gear Ratio	3	3.6	5	6	7.5	9	10	12.5	15	18	20	25	30	36	40	50	60	75	90	100	120	150	180
			r/min	600	500	360	300	240	200	180	144	120	100	90	72	60	50	45	36	30	24	20	18	15	12
6IDG□-6G	6GBD□MH	kgfcm	1.0	1.3	1.7	2.1	2.6	3.1	3.5	4.4	5.2	6.3	6.3	7.9	9.5	11.3	12.6	14.3	17.1	21.4	25.7	28.6	30.0	30.0	30.0
		N.m	0.10	0.12	0.17	0.20	0.26	0.31	0.34	0.43	0.51	0.61	0.62	0.77	0.93	1.11	1.23	1.40	1.68	2.10	2.52	2.80	2.94	2.94	2.94

Motor Model	Gearbox Model	Gear Ratio	200	250
			r/min	9
6IDG□-6G	6GBD□MH	kgfcm	30.0	30.0
		N.m	2.94	2.94

#### 50Hz

Motor Model	Gearbox Model	Gear Ratio	3	3.6	5	6	7.5	9	10	12.5	15	18	20	25	30	36	40	50	60	75	90	100	120	150	180
			r/min	500	417	300	250	200	166	150	120	100	83	75	60	50	41	37	30	25	20	16	15	12	10
6IDG□-6G	6GBD□MH	kgfcm	1.2	1.4	2.0	2.3	2.9	3.5	3.9	4.9	5.9	7.0	7.1	8.8	10.6	12.7	14.1	16.0	19.2	24.0	28.8	30.0	30.0	30.0	30.0
		N.m	0.11	0.14	0.19	0.23	0.29	0.34	0.38	0.48	0.57	0.69	0.69	0.86	1.04	1.24	1.38	1.57	1.88	2.35	2.82	2.94	2.94	2.94	2.94

Motor Model	Gearbox Model	Gear Ratio	200	250
			r/min	7.5
6IDG□-6G	6GBD□MH	kgfcm	30.0	30.0
		N.m	2.94	2.94

- 1) Enter the phase & voltage code in the box (□) within the motor model name.
- 2) Enter the gear ratio in the box (□) within the Gearbox model name.
- 3) A colored background indicates gear shaft rotation in the same direction as the motor shaft; a white background indicates rotation in the opposite direction.
- 4) The rotating speed is calculated by dividing the motor's synchronous speed (50Hz: 1,500r/min, 60Hz: 1,800r/min) by the gear ratio. The actual speed is 2~20% less than the displayed value, depending on the size of the load.

### Motor Images



## Dimensions

### MOTOR ONLY

- MOTOR MODEL: 6IDD□-6(-T) (NO FAN)

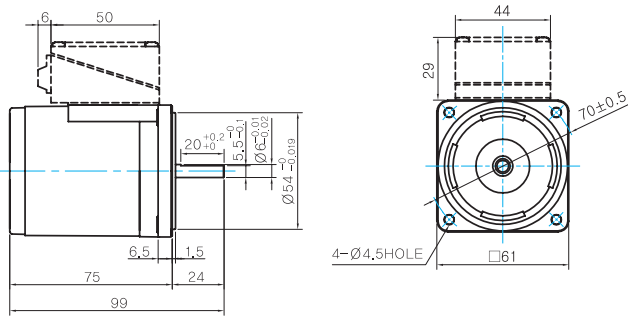

- MOTOR OUTPUT SHAFT

MODEL	SPEC
D-CUT TYPE	

### GEARED MOTOR

### G TYPE GEARBOX

- MOTOR MODEL: 6IDG□-6G (NO FAN)

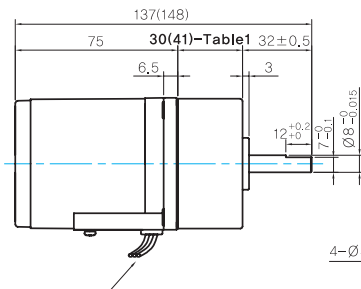

- GEARBOX MODEL: 6GBD□MH

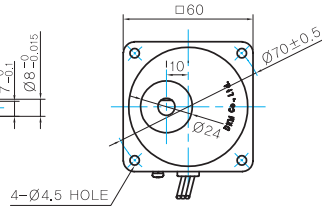

LEAD WIRE 300mm  
UL STYLE NO.3266 AWG NO.20

- GEARBOX OUTPUT SHAFT

MODEL	SPEC
D-CUT TYPE	

### WEIGHT

PART	WEIGHT(Kg)
MOTOR	0,7
GEAR BOX	
6GBD3MH ~ 6GBD18MH	0,3
6GBD20MH ~ 6GBD40MH	0,32
6GBD50MH ~ 6GBD250MH	0,34

- 30(41)-Table1

SIZE(mm)	GEAR RATIO
30	6GBD3MH - 6GBD18MH
41	6GBD20MH - 6GBD250MH

## Connection Diagrams

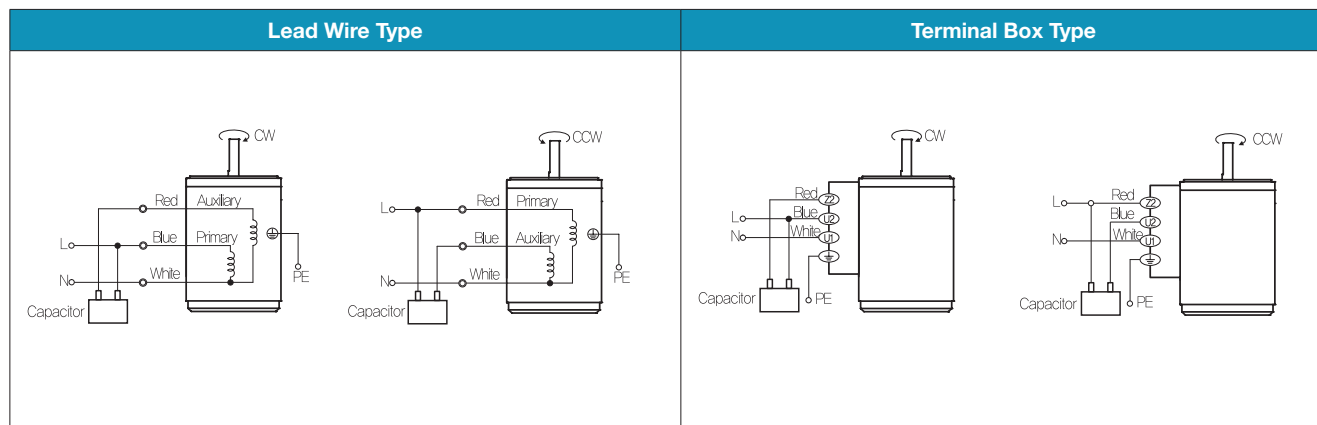

- The direction of motor rotation is as viewed from the shaft end of the motor.
- CW represents the clockwise direction, while CCW represents the counterclockwise direction.
- Change the direction of single phase motor rotation only after bringing the motor to a stop. If an attempt is made to change the direction of rotation while the motor is rotating, the motor may ignore the reversing command or change its direction after some delay.